



## Emergency Shut Off Device - for Schedule 40 or 80 Piping

### Description

Unique patented tool to "Add-A-Valve" or replace a defective valve on hot or cold water under pressure without shutting down or draining the system.

### Features

A high-tech fluid control device, designed to slash maintenance costs.

- Eliminates facility shutdowns
- Bottom cleanout can serve as line tap
- Comes complete with video, installation instructions and all accessories to complete installation
- Provides significant cost savings

### Attention

Limited Lifetime Warranty

Jomar® requires that the Add-A-Valve2® installer view Jomar's® CD/video on the proper installation of the Add-A-Valve2 device prior to attempting installation. Copies are available for viewing at the Add-A-Valve2® Distributors or Jomar website ([www.jomar.com](http://www.jomar.com)). The Add-A-Valve2® Installer will be solely responsible for any liability resulting from improper installation of any Add-A-Valve2® device. Jomar will not be responsible, nor will it exchange or provide a refund for any improperly installed Add-A-Valve2® device.



#### Architect/Engineer approval

Job Name \_\_\_\_\_ Date \_\_\_\_\_  
Model Specified \_\_\_\_\_ Quantity \_\_\_\_\_  
Variations Specified \_\_\_\_\_  
Customer/Wholesaler \_\_\_\_\_  
Contractor \_\_\_\_\_  
Architect \_\_\_\_\_

Note: Information subject to change without notice.

# ADD-A-VALVE 2®

## Emergency Shut Off Device - for Schedule 40 or 80 Piping



### Description

Unique patented tool to "Add-A-Valve" or replace a defective valve on hot or cold water under pressure without shutting down or draining the system.

### Dimensions in Inches

Computer No.	Size	A	B(open)	B(closed)	C	D
800-203ADD	1/2"	2.29	9.06	7.00	6.56	2.50
800-204ADD	3/4"	2.64	10.46	7.94	7.57	2.89
800-205ADD	1"	3.26	13.81	13.63	9.65	3.98
800-206ADD	1-1/4"	3.62	16.69	12.31	11.82	4.87
800-207ADD	1-1/2"	4.45	19.97	13.75	14.37	5.59
800-208ADD	2"	5.40	23.44	14.75	16.13	7.31

### Material Specification

No.	Part Name	Materials
1	Inner Stem	316 Stainless Steel
2	Inner Stem Clip	Steel
3	Outer Stem	Nickel Plated Brass
4	Bonnet	Nickel Plated Brass
5	Top Body Half	Nickel Plated Forged Brass
6	Washer	Steel
7	O-Ring (2)	Viton®
8	Bolt	304 Stainless Steel
9	O-Ring Holder	Brass
10	Plug	Viton®
11	Washer	Steel
12	Washer	Steel
13	Cutter Nut	304 Stainless Steel
14	Cutter	316 Stainless Steel
15	Seat Ring	304 Stainless Steel
16	Pilot Bit	304 Stainless Steel
17	Gasket	Viton®
18	Bottom Cap	Nickel Plated Brass

### Pressure Rating

250 PSI / 17 Bar Max.

220°F

### Warranty

The Company, for a period of one year from the date of shipment, warrants each product or system of its own manufacture to the original purchaser to be free from defects in material and workmanship under normal use, service and maintenance.

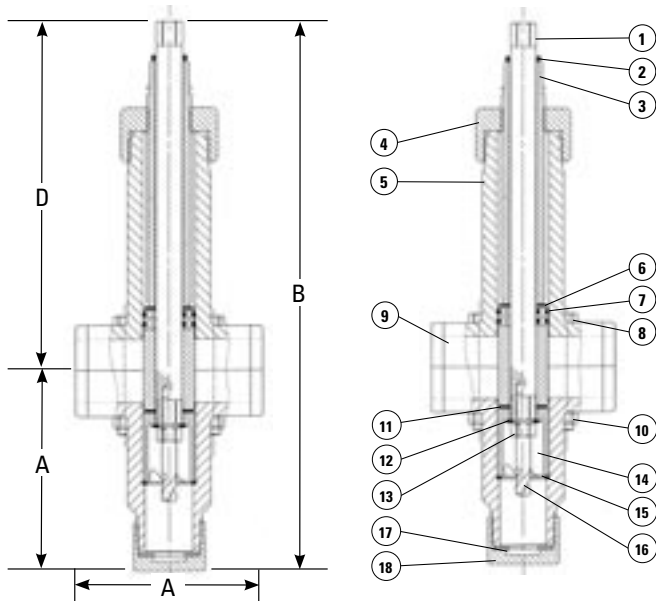

Note: Information subject to change without notice.



Jomar International Ltd.  
7243 Miller Drive  
Warren, MI 48092  
Phone: 800-325-5690  
Fax: 800-628-4194  
www.jomar.com