

# Direct Mount Ball Valve



**3-Way • Standard Port • Threaded Connection • 400 WOG • with ISO 5211 Direct Mounting Pad**



**A751T/L**

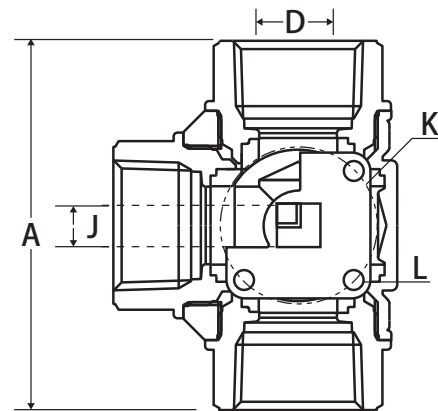
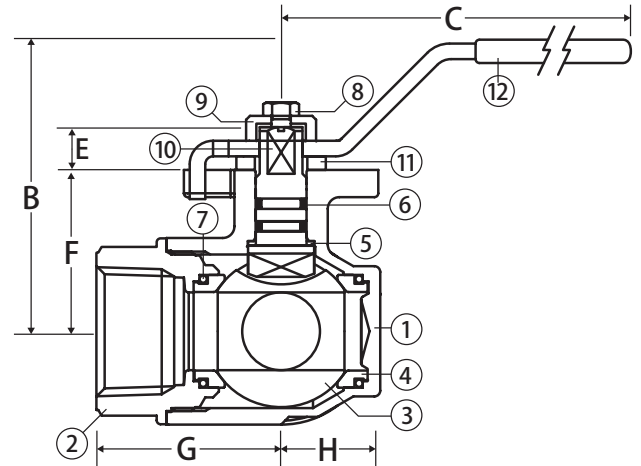

## Features

- ISO 5211 direct mounting pad
- Square valve stem for direct mounting to any ISO actuator
- Four seats design
- Blow-out proof stem
- Temperatures to 344°F
- Ships with lever handle



**WARNING:** This product can expose you to chemicals including lead, which is known to the State of California to cause cancer, and lead, which is known to the State of California to cause birth defects or other reproductive harm. For more information go to [www.P65Warnings.ca.gov](http://www.P65Warnings.ca.gov).

## Approvals

- ANSI B1.20.1

## Material Specifications

No.	Part	Materials
1	Body	Brass - CW617N
2	End Connection (3)	Brass - CW617N
3	Ball	Chrome Plated Brass - CW617N
4	Seat (4)	PTFE
5	Stem Seal	PTFE
6	O-ring (2)	Viton®
7	Body O-ring (4)	Viton®
8	Screw*	Steel
9	Bushing*	Brass - CW614N
10	Stem	Brass - CW614N
11	Washer*	Nylon
12	Handle*	Steel

\*Only included on lever operated valves

## Valve Seat Rating

400 WOG - 100 WSP

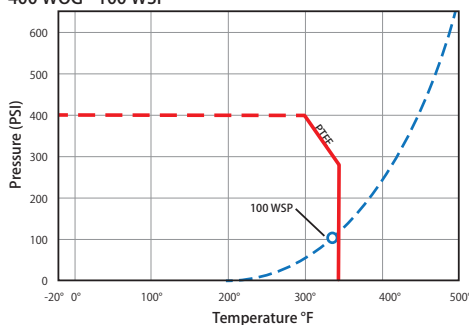

		Flow Options					
		T-Port			L-Port		
Lever Assembly							
	Position 1						
	Position 2						

## Dimensions

Part No.	Size	A	B	C	D	E	F	G	H	J	K	L	Torque
A750_-14*	1/4"	2.64	2.44	4.72	0.39	0.35	1.20	1.32	0.77	0.35	F03	0.23	54
A750_-38*	3/8"	2.64	2.44	4.72	0.43	0.35	1.20	1.32	0.77	0.35	F03	0.23	54
A751_-12	1/2"	2.87	2.44	4.72	0.43	0.35	1.20	1.44	0.77	0.35	F03	0.23	54
A751_-34	3/4"	3.19	2.52	4.72	0.59	0.35	1.29	1.60	0.87	0.35	F03	0.23	54
A751_-1	1"	3.74	2.95	6.69	0.79	0.43	1.63	1.87	1.00	0.43	F05	0.27	151
A751_-114	1-1/4"	4.39	3.17	6.69	0.98	0.43	1.85	2.20	1.22	0.43	F05	0.27	151
A751_-112	1-1/2"	4.86	3.66	6.69	1.26	0.43	2.34	2.43	1.79	0.43	F05	0.27	151
A751_-2	2"	5.73	4.43	9.05	1.57	0.59	2.90	2.87	1.75	0.55	F07	0.35	275
A750_-212*	2-1/2"	6.93	4.86	9.05	1.95	0.59	3.35	3.47	2.20	0.55	F07	0.35	381
A750_-3*	3"	7.08	4.86	9.05	1.95	0.59	3.35	3.54	2.20	0.55	F07	0.35	381

\_ = Must specify ball: T = T-Port, L = L-Port

\*1/4" - 3/8" and 2-1/2" - 3" are model A750, see [www.jomarvalve.com](http://www.jomarvalve.com) for detailed specification

Note: Torque is in (in-lb)