

Tru-Union PVC • Schedule 80 • Threaded and Solvent Connections • 150 WOG

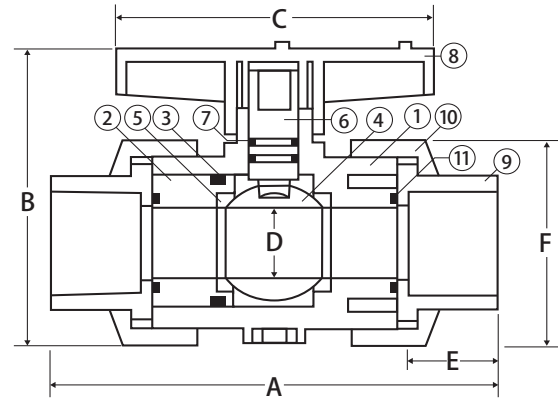

Union Connection - Socket:

Solvent cementing of socket end connections to pipe should be performed per ASTM specifications D2855-87. Cut pipe square. Chamfer and de-burr pipe. Surfaces must be cleaned and free of dirt, moisture, oil and other foreign material. Remove assembly nuts and end connectors from valve body. Slide assembly nuts, with threads facing valve, onto pipe to which the end connector is to be cemented. Apply primer to inside socket surface of end connector. Never allow primer or cement to contact valve ball or end connector O-ring sealing surfaces, as leaking may result. Use a scrubbing motion. Repeat applications may be necessary to soften the surface of the socket. Next, liberally apply primer to the male end of the pipe to the length of the socket depth. Again apply to the socket, and without delay, apply cement to the pipe while the surface is still wet with primer. Next apply cement lightly, but uniformly to the inside of the socket. Apply a second coat of cement to the pipe, and assemble the end connector to the pipe, rotating the end connector ¼ turn in one direction as it is slipped to full depth on to the pipe. The end connector should be held in position for approximately 30 seconds to allow the connection to “set”. After assembly wipe off excess cement. Full set time is a minimum of 30 minutes at 60° to 100° F. Full cure time should be based on the chart below.

Joint Cure Schedule:

The cure schedules are suggested as guides. They are based on laboratory test data, and should not be taken to be the recommendations of all cement manufacturers. Individual manufacturer’s recommendations for their particular cement should be followed.

Temperature Range during cure period	1/2”-3” Test Pressures		1-1/2”- 3” Test Pressures		4”-5” Test Pressures		6”-8” Test Pressures	
	180 psi	180-370 psi	180 psi	180-315 psi	180 psi	180-315 psi	180 psi	180-315 psi
60°-100°F	1h	6h	2h	12h	6h	18h	8h	24h
40°-60°F	2h	12h	4h	24h	12h	36h	16h	48h
20°-40°F	6h	36h	12h	72h	36h	4 days	3 days	9 days
10°-20°F	8h	48h	16h	96h	72h	8 days	4 days	12 days
<10°F	Extreme care should be exercised on all joints made where pipe, fittings, or cement is below 10°F							

A. It is important to note that at temperatures colder than 20F on sizes that exceed 3”, test results indicate that many variables exist in the actual cure rate of the joint. The data expressed in these categories represent estimated averages. In some cases, cure will be achieved in less time, but isolated test results indicate that even longer periods of cure may be required.

B. These cure schedules are based on laboratory test data obtained on Net Fit Joints (NET FIT=in a dry fit the pipe bottoms snugly in the fitting socket without meeting interference).

Union Connection - Threaded:

Wrap threads of pipe with Teflon tape of 3 - 3-1/2 mil thickness. The tape should be wrapped in a clockwise direction starting at the first or second full thread. Overlap each wrap by ½ the width of the tape. The wrap should be applied with sufficient tension to allow the threads of a single wrapped area to show through without cutting the tape. The wrap should continue for the full effective length of the thread. Pipe sizes 2” and greater will not benefit with more than a second wrap, due to the greater thread depth. To provide a leak proof joint, the pipe should be threaded into the end connection “hand tight”. Using a strap wrench only, (never use a stilson type wrench) tighten the joint an additional 1/2 - 1-1/2 turns past hand tight. Tightening beyond this point may induce excessive stress that could cause failure.

Material Specifications

No.	Part	Materials
1	Body	UPVC
2	Body Insert	UPVC
3	Body O-ring	Viton®
4	Ball	UPVC
5	Seat (2)	PTFE
6	Stem	UPVC
7	Stem O-ring (2)	Viton®
8	Handle	ABS Plastic
9	Tail Piece (2)	UPVC
10	Union Nut (2)	UPVC
11	Union O-ring (2)	Viton®

Union Connection - Flanged:

Flange bolts should be tight enough to slightly compress the gasket and make a good seal, without distorting or putting excessive stress on the flanges. Suitable washers should be used between the [bolt head and flange] and the [nut and flange]. Bolts should be tightened in alternating sequence.

Recommended Flange Bolt Torque

Flange Bolt			Torque		
Size	Diameter	ft-lbs	Size	Diameter	ft-lbs
1/2”	1/2”	10-15	2”	5/8”	15-25
3/4”	1/2”	10-15	2-1/2”	5/8”	20-25
1”	1/2”	10-15	3”	5/8”	20-25
1-1/4”	1/2”	10-15	4”	5/8”	20-25
1-1/2”	1/2”	10-15	6”	3/4”	30-40

Adjustment:

EXTREME CAUTION MUST BE TAKEN WHEN WORKING ON THIS VALVE. THE PIPING SYSTEM MUST BE DEPRESSURIZED AND DRAINED. PROPER CARE MUST BE TAKEN. CONSULT MSDS (MATERIAL SAFETY DATA SHEET) INFORMATION REGARDING YOUR SPECIFIC APPLICATION.

Remove the assembly nut and end connector from the upstream end of the body, or the complete valve body from the piping system. Turning the seal retainer clockwise “tightens” the seal on the ball while turning it counter-clockwise “loosens” the seal on the ball. The assembly nut should be installed on the valve “hand tight”. Using a strap wrench only, the joint may be tightened ½ to ¾ of a turn past “hand tight”.

Repair:

Follow the adjustment sequence and information above, but rotating the seal retainer completely in the “loosen” direction and remove it from the valve body. The O-rings and seals are now accessible for replacement using a “seal” repair kit. Carefully remove the O-rings from their respective locations, taking care not to scratch their sealing surfaces. Use a non-petroleum based lubricant to lubricate the O-rings, and re-assemble the valve.

Warning:

PLEASE READ THE FOLLOWING INFORMATION PRIOR TO INSTALLING AND USING (PVC/CPVC) JOMAR VALVES, STRAINERS, FILTERS, AND OTHER ASSOCIATED PRODUCTS. FAILURE TO FOLLOW THESE INSTRUCTIONS MAY RESULT IN SERIOUS INJURY.

1. Jomar guarantees its products against defective material and workmanship only. Jomar assumes no responsibility for damage or injuries resulting from improper installation, misapplication, or abuse of any product.
2. Jomar assumes no responsibility for damage or injury resulting from chemical incompatibility between its products and the process fluids to which they are subjected. Customer should always test to determine application suitability.
3. The maximum recommended fluid velocity through any Jomar PVC/CPVC product is eight feet per second. Higher flow rates can result in possible damage due to the water hammer effect. Also note that maximum operating pressure is dependent upon material selection as well as operating temperature.
4. Jomar products are designed primarily for use with non-compressible liquids. They should NEVER be used or tested with compressible fluids such as compressed air or nitrogen.
5. Systems should always be depressurized and drained prior to installing or maintaining Jomar PVC/CPVC products.
6. Temperature effect on piping systems should always be considered when the systems are initially designed. Piping systems must be designed and supported to prevent excess mechanical loading on Jomar equipment due to system misalignment, weight, shock, vibration, and the effects of thermal expansion and contraction.
7. Because of PVC and CPVC plastic products become brittle below 40F, Jomar recommends caution in their installation and use below this temperature.
8. Operating torque is affected by many factors including fluid chemistry, viscosity, flow rate and temperature. These should be considered when sizing electric or pneumatic actuator.
9. Due to differential thermal expansion rates between metal and plastic, transmittal of pipe vibration, and pipe loading forces **DIRECT INSTALLATION OF METAL PIPE INTO PLASTIC CONNECTIONS IS NOT RECOMMENDED**. Wherever installation of plastic valve into metal piping system is necessary, it is recommended that at least 10 pipe diameters in length of plastic pipe be installed upstream and downstream of the plastic valve to compensate for the factors mentioned above.