

Manual Balancing Valves • TBG & TRAB-BFF-Q

IMPORTANT

Please read the **Connection Guidelines** prior to installing these components. Failure to follow these instructions may damage the component and/or void the warranty.



TBG

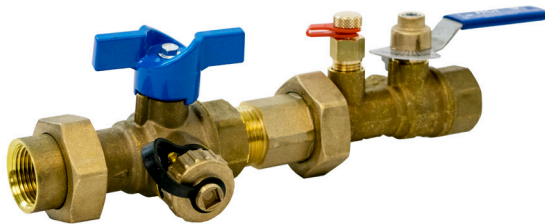

TRAB-BFF-Q

Installation:

1. The Terminator B is a unidirectional balancing device. The arrow on the valve body must be in the direction of flow.
2. For horizontal installations, the valve should be installed with the readout port on or above the horizontal center line. DO NOT install valve with the readout port facing down. Debris from the line can clog the port during the readout process. This can result in leaks.
3. There are no minimum upstream or downstream straight t-piping requirements for the Terminator B.

To Balance:

1. Take a reading using a differential pressure gauge calibrated in inches of water. Connect the "high" side line to the port marked "H" (closest to the union), and the "low" side line to the port marked "L" (closest to the handle).
2. The desired differential pressure can be found by referencing the location tag attached to the valve or by referring to the Terminator B pressure drop chart which is part of the spec sheet.
3. Throttle the valve until the desired differential pressure is indicated on the gauge. Loosen the memory stop on the valve handle, and rotate the stop counterclockwise until it touches the valves travel stop. Tighten the memory stop.

4. Record the indicator pad setting on balancing location tag attached to the valve. This will allow the valve to be properly reset in the event the memory stop setting is lost.

To Vent Air:

1. Make sure an optional air vent is installed in the accessory boss.
2. Close the valve between 45°-60°. Open vent to purge air from coil.

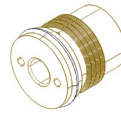

Needle nose pliers

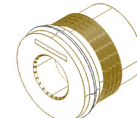

Flat head screwdriver

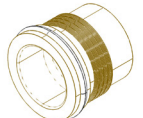

Rat tail file

To Replace Venturi:

1. Remove union nut, tailpiece and, o-ring from valve body
2. Using small needle nose pliers, a flat head screwdriver, or a rat tail file, depending on venturi model. Rotate the venturi counter-clockwise until the venturi threads disengage from the valve body.
3. Slide venturi insert out of the valve body.
4. Slide new venturi insert into the valve body until resistance is felt. Using the appropriate tool, rotate venturi 1 ½ turns counter-clockwise to ensure alignment.
5. Rotate venturi clockwise until the insert is snug. 4-7 full rotations, depending on venturi model.
6. To verify venturi is properly installed, sight down the interior of the valve. The high side PT port hole should be fully visible and unobstructed.
7. Reassemble o-ring, tailpiece and union nut onto valve body.

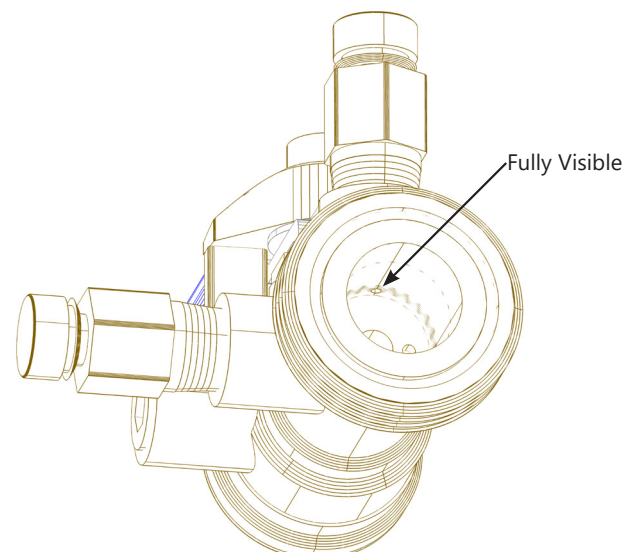

Pressure Drop Chart



CV of Valves

#4 Venturi: 1.30

Venturi Signal

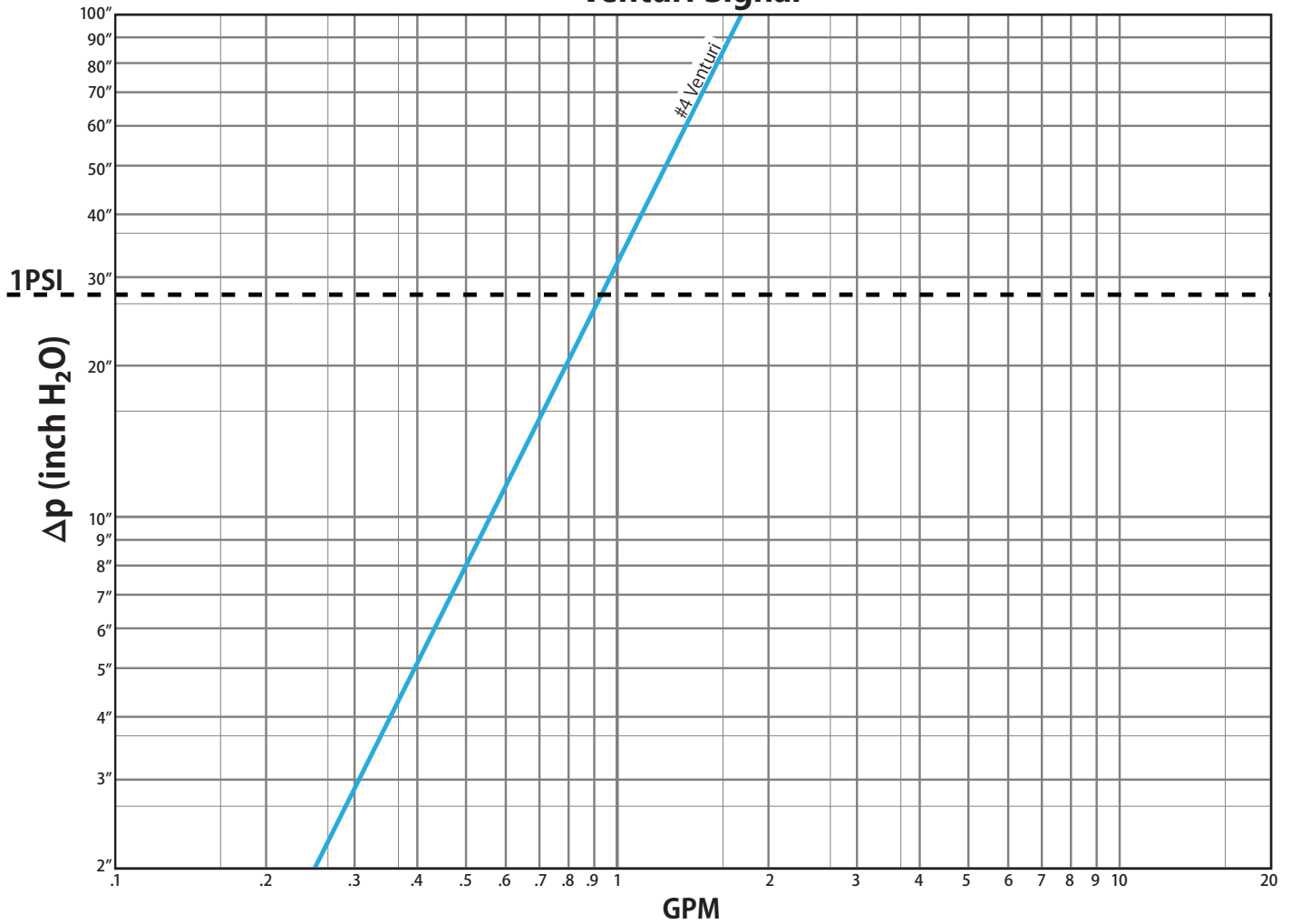

General Information

For proper operation, make sure that the system in which the valve is installed is free of debris, and that the water is devoid of entrained air. Air and debris will cause the balancing valves supplied by **Jomar Hydraulics** to function improperly. A strainer with a minimum 20 mesh screen is recommended upstream of all balancing valves to prevent clogging. High point and inline air vents are also recommended to ensure all entrained air is removed.

On chilled water systems, the test ports may seep after a reading is taken. Re-install the port cap and wait approximately one minute. Check the port. If seepage is still present, re-insert probe and remove slowly to allow port to seal.

Performance Guarantee:

Jomar Hydraulics guarantees to the original purchaser that the equipment of its manufacture will perform at the rated capacity as stated only when (1) properly installed, connected, started, operated and maintained in accordance with Company instruction(s) and/or information guide(s), as revised from time to time, (2) used for the applications specified and (3) used in the environments as specified or as limited. If equipment is part of a greater system, the Company accepts responsibility only for the equipment manufactured by it.

Water Treatment

Introduction of chemical cleaners, stabilizers and solvents into the systems may cause damage to the seats, seals, liners and gaskets or cause stress corrosion cracks in the product. Consult a water treatment specialist whenever introducing chemicals. It is important that you analyze all aspects of your systems components and the systems application with any introductions of chemicals into a system. It is solely the responsibility of the purchaser, contractor or engineer to review the material specification sheets for compatibility of these products. The documentation for the products described herein are subject to change at any time without notice. To obtain a copy of the current product specification sheets, **please visit www.jomarhydraulics.com or contact us at (586) 268-1220 or csr@jomar.com.**

Connection Guidelines

Threaded Connections

Teflon tape or pipe-joint compound (pipe dope) must be used when installing NPT threaded connections, however both tape and dope must not be used on the same connection. The use of Teflon tape in addition to a pipe dope compound can be dangerous. It can result in too much material between the flanks of the threads. Additionally, using both tape and dope can cause over tightening due to the lubricating effect of both materials.

Teflon Tape

Before installation, all mating pipe threads should be checked to ensure that there is no damage to the threads. Also make sure that all threads are clean from debris. PTFE tape should always be wrapped in the direction of the threads. Tape should be stretched tight around the threads to be ensured that it is securely attached. Each successive layer should overlap the previous layer by 1/2 to 2/3 and continue wrapping until the entire threaded portion of the pipe is covered. (minimum of 3 full turns). An excess amount of tape can prevent mating threads from fully engaging, therefore reducing the shear point of the threads. Be sure not to over torque the threaded valves during installation. Doing so could cause damage to be done to the valves or pipeline.

Pipe Dope

Be sure that the sealant is proper for the specific application in question and that all applicable codes are followed.

Factory Assembled Threaded Connections

All threaded bosses found on our components will contain either a PT port, accessory, accessory extension, or plug. All of the connections are made using Teflon tape or Loctite, and are factory tested up to 120 PSI to ensure a leak free joint. The removal or modification of any of these connections voids the warranty of the joint, as well as the warranty of the component. Contact us prior to modifying any factory assembled connections.