

Cast Iron Check Valve



Wafer Style • Double Door • Aluminum Bronze Disc • Class 125



F-591

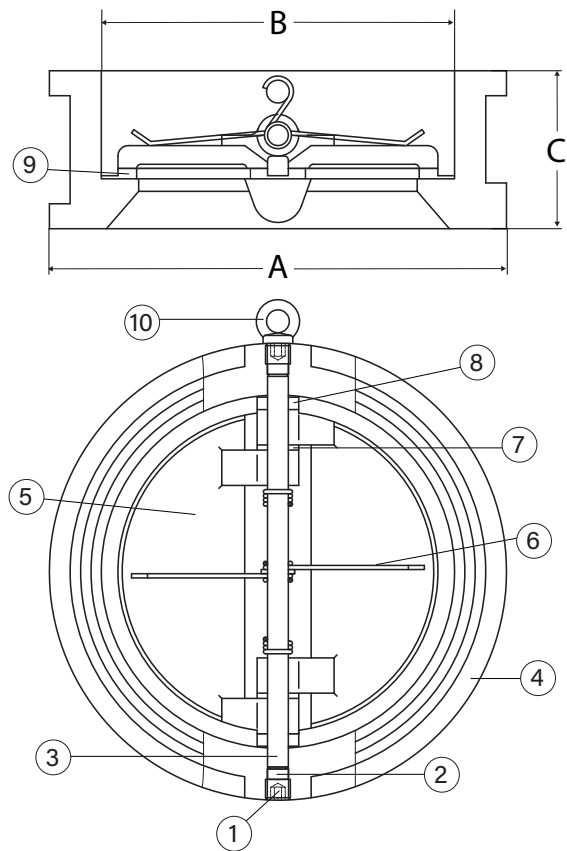

Approvals

- ANSI B16.1

Pressure Rating

- Class 125
- Lead Free Compliant

Temperature Range

- 14° F to 176° F

Install 5 pipe diameters minimum downstream from pump discharge or changes in direction to avoid flow turbulence. Flow straighteners may be required in extreme cases.

Note: On pump discharge, the preferred check valves are: inline, spring assisted, center-guided, lift checks.

Material Specifications

No.	Part	Materials
1	Screw	Carbon Steel
2	Sealing Ring	NBR/EPDM
3	Shaft	Stainless Steel - SS316
4	Body	CI/DI
5	Disc	Aluminum Bronze - C95400
6	Spring	Stainless Steel - SS316
7	Gasket	PTFE
8	Gasket	PTFE
9	Seat	NBR/EPDM
10	Lifting Ring (For 8" and above)	Carbon Steel

Dimensions

Part No.	Size	Weight	A	B	C	Cv
105-925	2-1/2"	5	4.88	3.15	2.17	120
105-903	3"	8	5.46	3.70	2.27	226
105-904	4"	9	6.57	4.61	2.52	404
105-906	6"	20	8.58	6.37	2.99	1075
105-908	8"	33	10.98	8.82	3.50	1920
105-910	10"	56	13.15	10.43	4.49	3360
105-912	12"	90	16.1	12.2	4.49	5320

WARNING: This product can expose you to chemicals including lead, which is known to the State of California to cause cancer, birth defects or other reproductive harm. For more information go to www.P65Warnings.ca.gov.